

INSTRUCTIONS FOR INSTALLING SARGENT 2828 SERIES RIM EXIT DEVICE

US PATENT No 268003
CANADIAN PATENT No RD1981

SARGENT
ASSA ABLOY

ASSA ABLOY, the global leader in door opening solutions

CAUTION!

BEFORE STARTING:

- INSTALL MULLION IF USED;
- DOOR SHOULD BE FITTED AND HUNG;
- CHECK BOX LABEL FOR SIZE OF EXIT DEVICE.

AVAILABLE STOCK LENGTHS:

- LENGTH "E" - 32" DOOR, NO CUT REQUIRED.
CAN BE CUT TO FIT DOORS DOWN TO 24" WIDE.
- LENGTH "F" - 36" DOOR, NO CUT REQUIRED.
CAN BE CUT TO FIT DOORS DOWN TO 30" WIDE.
- LENGTH "G" - 48" DOOR, NO CUT REQUIRED.
CAN BE CUT TO FIT DOORS DOWN TO 36" WIDE.

IMPORTANT:

1. FOR RIM CYLINDER APPLICATIONS:
INSTALL CYLINDER TAIL WASHER TO CYLINDER TAIL PIECE. SEE STEP THREE FOR DETAILS.
2. CLEAR AWAY ANY RAISED PROJECTIONS
TO ALLOW EXIT DEVICE TO REST ON
FLAT SURFACE OF THE DOOR.

HORIZONTAL
REFERENCE LINE
(ϕ OF CHASSIS AND
RAIL ASSEMBLY)

641 STRIKE SHOWN

VERTICAL REFERENCE LINE
(ϕ OF CHASSIS)

RAIL ASSEMBLY

CENTER
CHASSIS
ASSEMBLY

CYLINDER
TAIL WASHER

END CAP

MOUNTING BRACKET

"LOCK DOWN KEY"
TO OPERATE: DEPRESS PUSHRAIL;
INSERT HEX KEY AND TURN CLOCKWISE.

THIS EXIT DEVICE IS NON-HANDED

RIGHT HAND
REVERSE BEVEL

LEFT HAND
REVERSE BEVEL

SECOND PREPARE DOOR

APPLY TEMPLATE ON THE DOOR ALONG REFERENCE LINES AND TAPE IT WITH SUPPLIED TAPE. IF DOOR ALREADY HAS ANSI DOOR PREP (161 CUT-OUT), OR HAS 2 1/8" DIA HOLE AT 2 3/4" BACKSET, POSITION TEMPLATE OVER EXISTING HOLE & MARK FOR 4 CHASSIS MOUNTING HOLES. SPOT AND DRILL HOLES.

HORIZONTAL REFERENCE LINE
(ϕ OF CHASSIS AND RAIL ASSEMBLY)

VERTICAL REFERENCE LINE
(ϕ OF CHASSIS)

THIRD APPLY HARDWARE

K-HTB APPLICATIONS

THRUBOLT OUTSIDE
TRIM (IF USED) TO
CHASSIS

WHEN CYLINDER IS USED -
IT MUST BE POSITIONED IN
THE MIDDLE OF TRIM, AS
ILLUSTRATED

ATTENTION! SLIDE WASHER
OVER THE CYLINDER TAIL BEFORE
BACK PLATE INSTALLATION

FOR RIM CYLINDER ONLY APPLICATION

ATTENTION:
USE STANDARD SHIMS FOR
CENTER CHASSIS MOUNTING

MACHINE SCREW RIM CYLINDER ASSEMBLY

CYLINDER TAIL PIECE

CYLINDER BACK PLATE

CYLINDER TAIL WASHER

ATTENTION:
SLIDE CYLINDER TAIL
WASHER OVER THE
CYLINDER TAIL PIECE
BEFORE ATTACHING
CYLINDER BACK PLATE
TO THE DOOR

KNOB TRIM APPLICATIONS

TRIM IS NON HANDED.

1. SCREW THE ROSE DOWN ALL THE WAY.
2. WITH KEYHOLE FACING DOWN, POSITION TRIM IN CROSS BORE HOLE, AND ATTACH TO CHASSIS WITH (2) #10-32 FILLISTER HD. MACHINE SCREWS.

**FOR LEVER TRIM APPLICATIONS, SEE INSTRUCTION SHEET A7274 PACKED W/LEVER TRIM.

FIRST MARK VERTICAL AND HORIZONTAL REFERENCE LINES ON THE DOOR

B IDENTIFY TYPE OF INSTALLATION TO DETERMINE LOCATION OF VERTICAL ϕ

SINGLE DOOR

DOOR

"A"

VERTICAL REFERENCE LINE
(ϕ OF CHASSIS)

- IF USE 641 STRIKE DIM. "A" = 2 1/4"
- IF USE 613 STRIKE DIM. "A" = 1 3/4"
- IF USE 642 STRIKE DIM. "A" = 1 1/2"

DOUBLE DOOR WITH 980 MULLION

DOOR DOOR

"A"

VERTICAL REFERENCE LINE
(ϕ OF CHASSIS)

- IF USE 641 STRIKE DIM. "A" = 2 1/4"

FOURTH APPLY RAIL ASSEMBLY

- CHECK BOX LABEL. IF CUTTING IS NOT REQUIRED PROCEED TO STEP "B".
- IF CUTTING IS REQUIRED, CONTINUE WITH STEP "A".

A DETERMINE CUT OFF DIMENSION "X" BY SUBTRACTING 1 3/4" FROM DIMENSION "Y". MARK CUT OFF POINT ON MOUNTING RAIL.

FOR DOORS WITH STILE RAIL MUST OVERLAP STILE BY 1/2" MIN.

VERTICAL REFERENCE LINE
(ϕ OF CHASSIS)

1 3/4" MIN.

"X"

"Y"

HOLD DOWN PUSH RAIL,
CUT OFF AND DEBURR.

CAUTION:
DO NOT CUT CLOSER THAN
3 1/2" FROM THE CONNECTING
ARM PIVOT IN THE PUSH RAIL

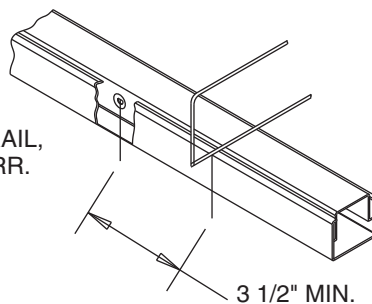

B DEPRESS ARM INTO RAIL OPENING AND SLIDE RAIL ONTO CHASSIS. LEVEL RAIL AND FASTEN MOUNTING PLATE

LEVEL MOUNTING PLATE

ATTACH RAIL ASSEMBLY TO THE CHASSIS WITH TWO #8 TRUSS HEAD MACHINE SCREWS.

PLACE MOUNTING PLATE TIGHT AGAINST RAIL AND ATTACH IT TO THE DOOR WITH THREE #10 ROUND HEAD SCREWS

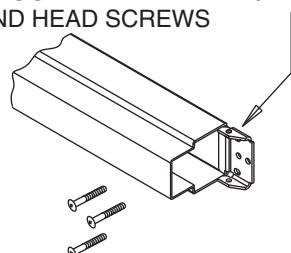

FIFTH APPLY COVERS AND STRIKE

ATTACH COVER TO CHASSIS WITH FOUR #8 TRUSS HEAD MACHINE SCREWS

ATTACH STRIKE WITH TWO OUTER SCREWS AND TWO STAR WASHERS. ADJUST FOR PROPER POSITION.

ATTACH END CAP TO MOUNTING PLATE WITH TWO COVER SCREWS

FOR EXIT ONLY APPLICATIONS

USING RETAINING RING PLIERS (NOT SHOWN) OR SCREWDRIVER TO REMOVE RETAINING RING FROM THE CAM AND CAM FROM THE CENTER CHASSIS ASSEMBLY FOR FLUSH MOUNTING.

ATTACH CHASSIS WITH FOUR #10 WOOD OR MACHINE SCREWS

SCREWDRIVER CENTER CASE CHASSIS ASSEMBLY

RETAINING RING CAM

A6368 M

INSTRUCTIONS FOR INSTALLING SARGENT 12-2828 SERIES FIRE EXIT DEVICE

US PATENT No 268003
CANADIAN PATENT No RD1981

SARGENT
ASSA ABLOY

ASSA ABLOY, the global leader
in door opening solutions

CAUTION!

BEFORE STARTING:

- INSTALL MULLION IF USED;
- DOOR SHOULD BE FITTED AND HUNG;
- CHECK BOX LABEL FOR SIZE OF EXIT DEVICE.

AVAILABLE STOCK LENGTHS:

- LENGTH "E" - 32" DOOR, NO CUT REQUIRED.
CAN BE CUT TO FIT DOORS DOWN TO 24" WIDE.
- LENGTH "F" - 36" DOOR, NO CUT REQUIRED.
CAN BE CUT TO FIT DOORS DOWN TO 30" WIDE.
- LENGTH "G" - 48" DOOR, NO CUT REQUIRED.
CAN BE CUT TO FIT DOORS DOWN TO 36" WIDE.

IMPORTANT:

1. FOR RIM CYLINDER APPLICATIONS:
INSTALL CYLINDER TAIL WASHER TO CYLINDER
TAIL PIECE. SEE STEP THREE FOR DETAILS.
2. CLEAR AWAY ANY RAISED PROJECTIONS
TO ALLOW EXIT DEVICE TO REST
ON FLAT SURFACE OF THE DOOR.

HORIZONTAL
REFERENCE LINE
(\varnothing OF CHASSIS AND
RAIL ASSEMBLY)

649 STRIKE SHOWN

VERTICAL REFERENCE LINE
(\varnothing OF CHASSIS)

CENTER
CHASSIS
ASSEMBLY

RAIL ASSEMBLY

CYLINDER
TAIL WASHER

END CAP

MOUNTING BRACKET

THIS EXIT DEVICE
IS NON-HANDED

OUT

RIGHT HAND
REVERSE BEVEL

LEFT HAND
REVERSE BEVEL

SECOND PREPARE DOOR

APPLY TEMPLATE ON THE DOOR ALONG REFERENCE
LINES AND TAPE IT WITH SUPPLIED TAPE.
IF DOOR ALREADY HAS ANSI DOOR PREP
(161 CUT-OUT), OR HAS 2 1/8" DIA HOLE AT 2 3/4"
BACKSET, POSITION TEMPLATE OVER EXISTING
HOLE & MARK FOR 4 CHASSIS MOUNTING HOLES.

SPOT AND DRILL HOLES.

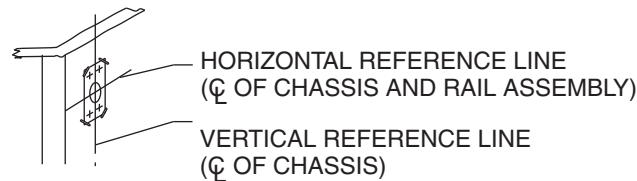

FIRST A MARK VERTICAL AND HORIZONTAL REFERENCE LINES ON THE DOOR

B IDENTIFY TYPE OF INSTALLATION TO DETERMINE LOCATION OF VERTICAL \varnothing

SINGLE DOOR

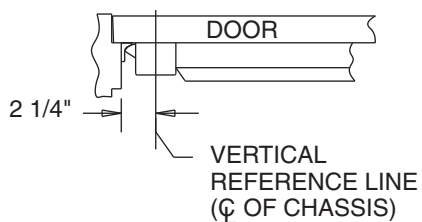

DOUBLE DOOR WITH 12-980 MULLION

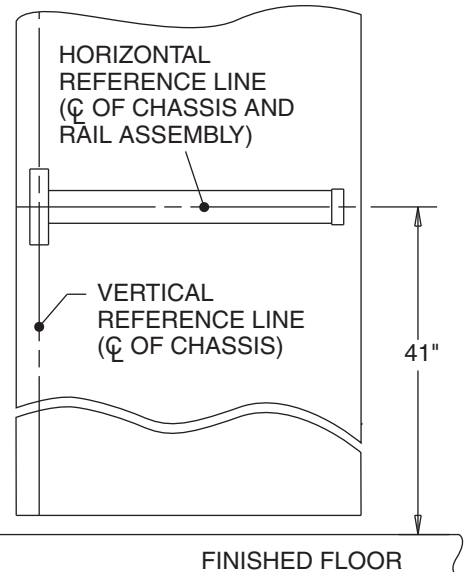
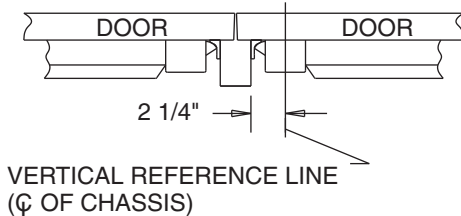

THIRD APPLY HARDWARE

K-HTB APPLICATIONS

THRUBOLT OUTSIDE
TRIM (IF USED) TO
CHASSIS

WHEN CYLINDER IS USED -
IT MUST BE POSITIONED IN
THE MIDDLE OF TRIM, AS
ILLUSTRATED

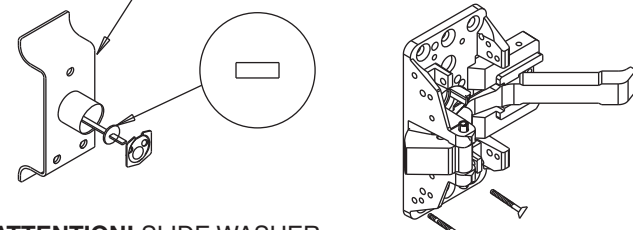

ATTENTION! SLIDE WASHER
OVER THE CYLINDER TAIL BEFORE
BACK PLATE INSTALLATION

FOR RIM CYLINDER ONLY APPLICATION

ATTENTION:
USE STANDARD SHIMS FOR
CENTER CHASSIS MOUNTING

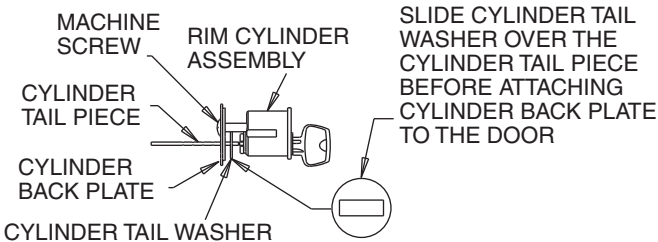

FOURTH APPLY RAIL ASSEMBLY

- CHECK BOX LABEL. IF CUTTING IS NOT REQUIRED PROCEED TO STEP "B".
- IF CUTTING IS REQUIRED, CONTINUE WITH STEP "A".

- A DETERMINE CUT OFF DIMENSION "X" BY SUBTRACTING 1 3/4" FROM DIMENSION "Y".
MARK CUT OFF POINT ON MOUNTING RAIL.

FOR DOORS WITH STILE RAIL MUST
OVERLAP STILE BY 1/2" MIN.

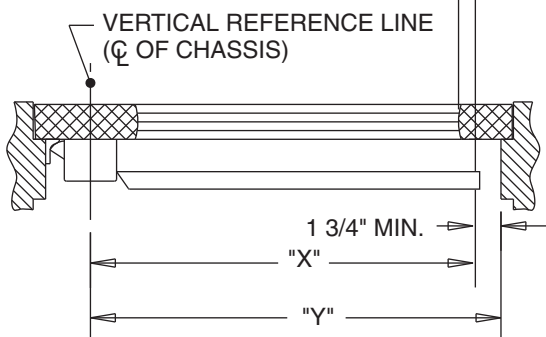

HOLD DOWN PUSH RAIL,
CUT OFF AND DEBURR.

CAUTION:
DO NOT CUT CLOSER THAN
3 1/2" FROM THE CONNECTING
ARM PIVOT IN THE PUSH RAIL

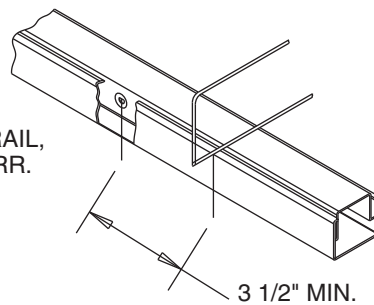

- B DEPRESS ARM INTO RAIL OPENING AND SLIDE RAIL ONTO CHASSIS.
LEVEL RAIL AND FASTEN MOUNTING PLATE

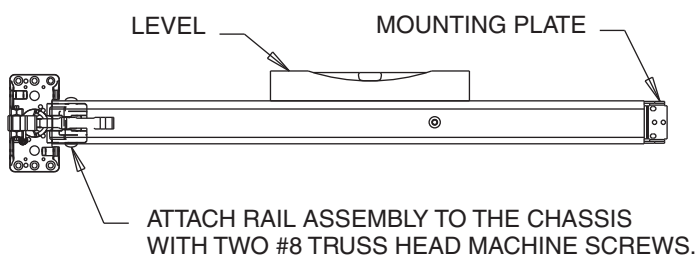

PLACE MOUNTING PLATE TIGHT
AGAINST RAIL AND ATTACH IT TO
THE DOOR WITH THREE #10
ROUND HEAD SCREWS

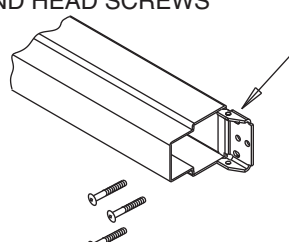

KNOB TRIM APPLICATIONS

- TRIM IS NON HANDED.
1. SCREW THE ROSE DOWN ALL THE WAY.
 2. WITH KEYHOLE FACING DOWN, POSITION TRIM
IN CROSS BORE HOLE, AND ATTACH TO CHASSIS
WITH (2) #10-32 FILLISTER HD. MACHINE SCREWS.

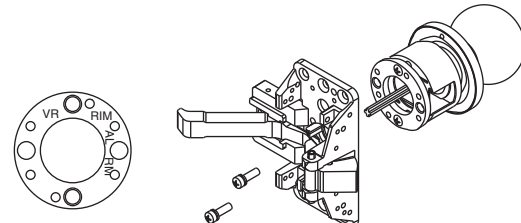

**FOR LEVER TRIM APPLICATIONS, SEE INSTRUCTION
SHEET A7274 PACKED W/LEVER TRIM.

FIFTH APPLY COVERS AND STRIKE

ATTACH COVER TO CHASSIS WITH
FOUR #8 TRUSS HEAD MACHINE SCREWS

ATTACH STRIKE WITH TWO STRIKE
SCREWS AND ADJUST FOR PROPER
POSITION. DRILL AND TAP TWO ADDITIONAL
HOLES AND FASTEN STRIKE IN PLACE

ATTACH END CAP TO
MOUNTING PLATE
WITH TWO COVER
SCREWS

FOR EXIT ONLY APPLICATIONS

USING RETAINING RING
PLIERS (NOT SHOWN) OR
SCREWDRIVER TO REMOVE
RETAINING RING FROM THE
CAM AND CAM FROM THE
CENTER CHASSIS ASSEMBLY
FOR FLUSH MOUNTING.

ATTACH CHASSIS
WITH FOUR #10
WOOD OR
MACHINE SCREWS

RETAINING RING

CENTER CASE
CHASSIS
ASSEMBLY

CAM

A6368 M